

# CB33 - Cheek Brace for Keltec CP33

Croix Systems

<http://croix.systems>

Thank you for purchasing the CB33 cheek brace.

## Warnings

- Not a stock, not designed or intended to contact the shoulder in any way.
- Use of this product is at your own risk.
- Do not rely solely on the hand index point to stop your hand from moving in front of the muzzle.

## Installation - Cheekrest

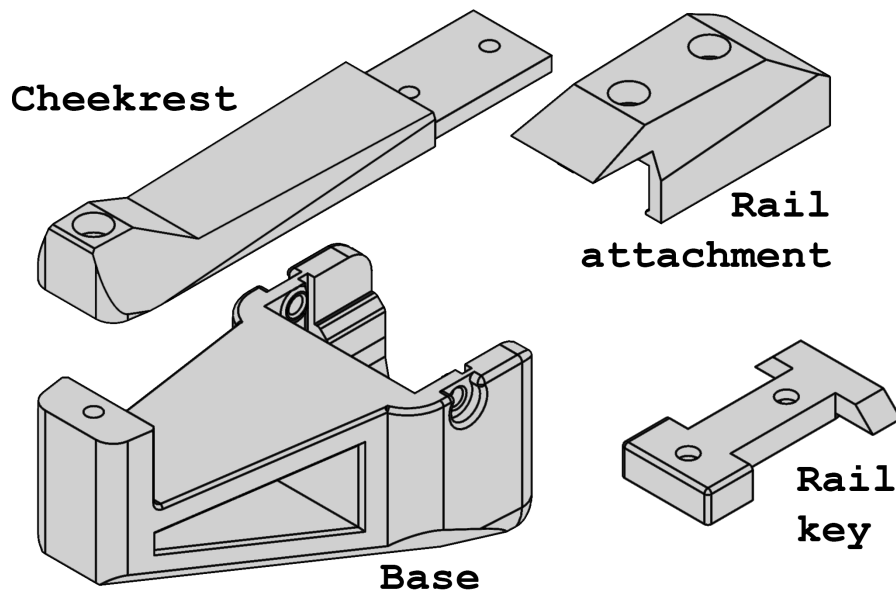

Figure 1: Cheekrest components

1. **Verify that the weapon is unloaded.**
2. Remove the rear iron sight. Using a small punch or paper clip, remove the roll pin holding the rear sight assembly to the frame.
3. Find the rearmost frame screws between the charging handle and the sling studs. Using the included 5/64" hex key, remove both screws.
4. Slide the cheekrest base (Figure 1: **Base**) upwards. The sling studs will slide into vertical cutouts in the cheekrest base.
5. Using the included 5/64" hex key, reinstall both frame screws. Loctite is recommended.

6. Insert the rail alignment key (Figure 1: **Rail key**) into the void previously occupied by the rear sight assembly.
7. Lock the charging handle to the rear and keep it extended. Slide the rail attachment (Figure 1: **Rail attachment**) onto the top picatinny rail until it is flush with the back of the rail alignment key. The two screwholes should be aligned between the rail key and rail attachment.
8. Slide the cheekrest top rail (Figure 1: **Cheekrest**) rearwards into the slot between the rail attachment and rail key. The screwhole at the back of the cheekrest top rail should be aligned with the screwhole at the back of the cheekrest base.
9. Using the included M3 hex key, install the long screw to clamp the cheekrest top rail to the cheekrest base. Install two short screws to clamp the cheekrest top rail, the rail attachment, and the rail key together.

## Installation - Brass deflector

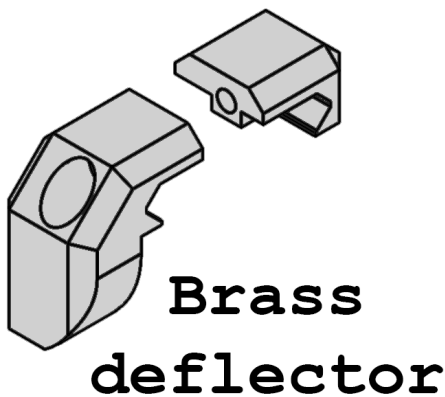

Figure 2: Brass deflector

1. **Verify that the weapon is unloaded.**
2. Clamp the two halves of the brass deflector onto the top rail, with the straight portion of the deflector flush with the end of the ejection port.
3. Using the included M3 hex key, install the short screw to clamp the two halves together.

## Installation - Hand index point

A small index point that mounts in place of the front sight.

The smaller of the two indices will fit holstered into the PHLster Floodlight 1 holster.

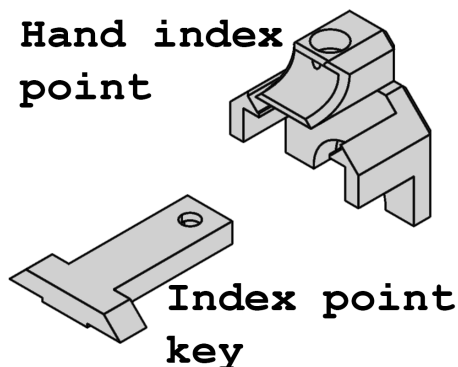

Figure 3: Hand index point (Floodlight OWB version)

1. **Verify that the weapon is unloaded.**
2. Using the included 5/64" hex key, remove the front sight retaining screw.
3. The front sight will then lift out of the sight groove.
4. Insert the hand index point alignment key (Figure 3: **Index point key**) into the void previously occupied by the front sight.
5. Slide the desired size of hand index point onto the top rail. The screw hole on the top index point should be aligned with the nut installed in the hand index point.
6. Using the included M3 hex key, install the short screw to clamp the hand index point onto the alignment key.